

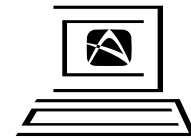

INSTALLATION/ OWNERS MANUAL

MOBILE THEATER
SERIES WITH
SWIVEL MOUNT
TWEETER

5-1/4", 6.5"
TWO-WAY SPEAKERS



For Customer Service
Visit Our Website At
www.audiovox.com
Product Information, Photos,
FAQ's, Owner's Manuals

SPECIFICATIONS

MODEL	PST-52	PST-65
Nominal Diameter	5 1/4"	6 1/2"
Description	2-Way	2-Way
Impedance	4 Ohms	4 Ohms
Freq. Response (Hz)	60-20,000	50-20,000
Sensitivity (dB)	90	90
Power Handling	120 Watts	135 Watts
Magnet Weight	10 oz.	10 oz.
Tweeter	19 mm	19 mm
Woofer Size	5 1/4"	6 1/2"
Installation		
Mounting Depth	2 5/8"	2 3/4"

PRE-INSTALLATION TIPS

Before beginning your installation, read the following tips on proper placement of speakers and how to obtain the best sound from the speakers you have selected.

No. 1:

Always try to have the speakers aimed at the listener. Never install speakers in a manner that would direct sound toward the floor of the car. The only exception to not aiming a speaker would be the rear deck (package shelf behind rear seat). The natural curve of the rear window, combined with the wide-dispersion tendency of bass sounds, allows woofers to perform exceptionally well in this location. This is not true for high-frequency sounds which will be absorbed by the roof liner long before they reach your ears.

No. 2:

High and mid-frequency sounds are very directional (the higher the frequency, the more directional it is). This simply means that a tweeter or mid-range speaker pointing toward the floor (or roof) will only be clearly heard in the direction at which it is pointed. For this reason, it is critical that tweeters and mid-range speakers always be installed so they aim in toward the passenger area and as high in the car as possible (on top of dash or high up in door panels). Never install tweeters low in the car.

No. 3:

Select **solid** mounting panels! Always make certain the selected panel is solid and securely attached to the car. Clipped-in plastic

or fire panels make poor mounting surfaces and tend to vibrate when used. This is far more critical when installing large power producing woofers. **Mount your speakers securely!** If the speaker has four mounting holes, use all of them.

No. 4:

Woofers need “breathing” room! For a speaker to perform efficiently, it must move large amounts of air. If you restrict this airflow (try to fit a large speaker in a small space or if you undercut the recommended mounting hole size), you won’t have an efficient speaker. Conversely, the enclosure you mount them in should be somewhat sealed. In other words, if you mount speakers in door panels, don’t cut any extra holes in the door.

No. 5:

Tweeters can go in places other speakers can’t. They don’t need “breathing” room or reinforced mounting panels. All they require is directional placement. (See tip No. 2.)

No. 6:

Never let any part of the speaker (except the mounting flange) touch any part of the car. You’ll be amazed what noises a speaker (and your car) can produce when one touches the other.

No. 7:

Don’t skimp on the quality of the speaker wiring. All Audiovox speakers include wiring rated to properly transmit the normal power load the speaker is designed for.

INSTALLATION INSTRUCTIONS

CAUTION: Do not mount the speakers in the following locations:

- Where the door window glass comes in contact with the speaker.
- Where the window crank handles or gear assemblies come in contact with the speaker when rotated.
- Where the speakers come in contact with the trunk springs, shock towers, or trunk lid.
- Where the speakers come in contact with gas tanks or fuel lines.
- Where the speakers come in contact with the rear window glass, car wall, etc.

We strongly recommend that you read these instructions first before you commence speaker installation. If the instructions appear to be too difficult, or if you lack any of the equipment necessary to finish the job, perhaps it would be more prudent to refer the installation to a qualified, car stereo professional.

Ease of Installation - The car manufacturer provides at least two, and possibly four, pre-cut openings in all cars. When only two are provided, one is usually in the rear deck and the other is in the front dash. Provisions for four speakers usually include two rear deck openings and two door or dash openings. A car manufacturer picks speaker locations that simplify installation and fit available spaces. They are not always the best places for sound reproduction.

Using Factory Openings - The one advantage to using the factory openings is you avoid having cut sheet metal, as the holes are pre-punched. You normally have only to cut away thin plastic or fiber panels that conceal the openings. Openings near the floor should be avoided if at all possible.

Be Innovative - If you're mechanically inclined, remove door panels, dash, side panels, etc., and really get into the basic construction of the car. You'll be amazed at the vast amount of good-to-excellent speaker locations a car can conceal.

If You Don't Wish to Cut Holes - Consider the hang-on or surface-mount type of speakers. Just pick a reasonably flat panel, drill a few holes, fasten a few screws, and you're listening to stereo.

INSTALLING ROUND SPEAKERS IN DOORS OR FLAT SURFACES

Most cars are factory-equipped with round speaker openings in door panels, kick panels and occasionally, rear deck panels.

If you decided on a door location for mounting speakers, the following procedure should be followed:

1. Examine the door panel thoroughly. Observe movement of window crank (no power windows), door latches, etc. Obviously, you don't want to install a speaker where the arc of a moving window crank (or electric window frame) would interfere with the speaker grille. Avoid all areas that might cause interference with the normal functions of the door assembly.

CAUTION: By removing the door upholstery panel, you may find several alternate locations higher up on the door. Watch out for window mechanisms; even professional installers have mounted a speaker and then found out it interfered with some moving part.

2. It is highly recommended that the padded door panel be removed. This can be accomplished by removing the window crank (usually held by a screw or "C" clip found behind the crank), unless the car is equipped with power windows.

If necessary, remove the door opening handle any accessory. Unless screws are holding the door panel to the door frame, which is very rare, you will find that most door panels are secured by spring clips.

3. Using a broad flat tool between door and door panel, unfasten spring clips. If a few clips are bent when removing them, a pair of pliers will easily re-form them. Once all clips are unfastened, lift off door panel.

NOTE: On cars equipped with power windows, seats, etc., it may be necessary to free the power switch plate, usually mounted to the driver's side arm rest, in order to fully separate the door panel from the frame.

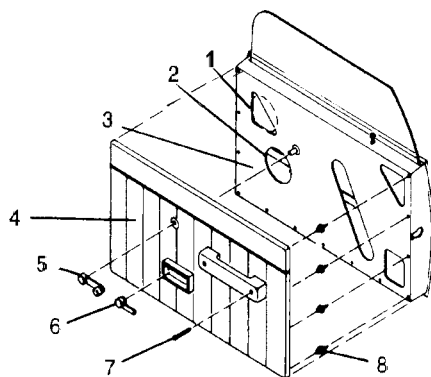

Removing the Door Panel

1. This opening would have to be enlarged per dotted line
2. Possible speaker opening
3. Remove paper liner
4. Padded door panel
5. Window crank

6. Door latch
7. Screws
8. Clip pins

Selecting Speaker Location

After removing the door panel, you are ready to select a location for the speaker. Make this selection as follows:

1. When the steel sub-door panel is exposed, you may find the panel completely or partially covered by brown or black paper secured with a sticky-black, tar-like adhesive. Do not tear this paper off. It is there to insulate the door, to trap moisture, and to reduce wind noise.
2. Carefully unpeel the paper. (Do not do this if speaker openings are exposed.) You should now be able to see all the varied size openings available in the sub-steel door. The reason for exposing all the existing holes is to avoid cutting metal unless it is absolutely necessary.
3. Now determine which existing holes will accommodate your speakers. Temporarily install the window crank; place the speaker into the opening and, while holding the speaker in place, fully raise and lower the window. Check that no moving part touches the speaker while opening or closing the window. Then open and close the door and inspect for speaker interference.
4. If you are satisfied with the selected location, you can begin the installation process. But first, visually check the padded door panel to verify that nothing on it will interfere with installing the speaker grille (an armrest, for example).
5. If the selected location is acceptable, proceed to **Speaker Mounting**, step 2; if the location needs to be changed, continue with **Speaker Mounting**, step 1.

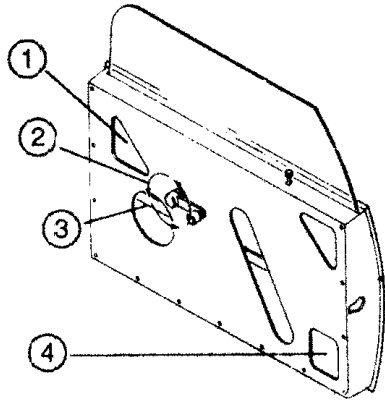

Selecting the Speaker Location

1. This is a good speaker location, but to use it, you'll have to enlarge the existing hole
2. Check for free window crank movement
3. Check for possible braces behind selected area with window down **and** up
4. This is a poor location for a speaker installation; it is too low and behind driver's hearing area

Speaker Mounting

Let's assume you didn't find a suitable opening, but you want to install the speakers in the doors. This usually means you will have to cut a speaker opening in the sub-metal (or at least enlarge an existing opening). Cutting metal is not for the timid or unqualified installer. If in doubt, proceed to your nearest garage or stereo installation center and let the "pros" do it for you.

If you intend to tackle the job yourself, break out your best metal-cutting tools (no torches please); use nibblers, saws or heavy snips. You'll need a file too. Prepare the opening as follows:

1. Using the template provided (we'll assume you've already made all the necessary checks and you've not going to cut through the door release mechanism), mark the speaker opening on the door panel. Now carefully cut the opening and drill the required holes.

NOTE: Whether you're using an existing hole, or have just cut or modified an existing opening as described above, you are now ready for speaker installation.

2. Place the speaker into the opening and check for proper fit. Remove the speaker and replace the paper door liner previously removed.

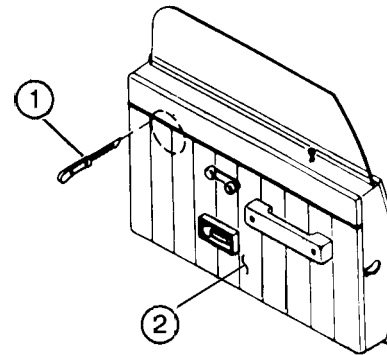

Cutting Door Padding

1. Use a sharp knife to cut through padding to expose speaker hole
2. Replace door panel and paper liner

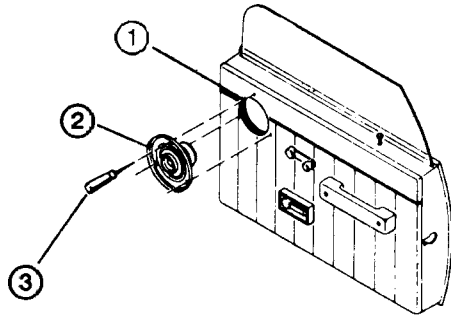

Piercing Speaker Mounting Holes

1. Opening
2. Speaker
3. Pierce the speaker mounting holes

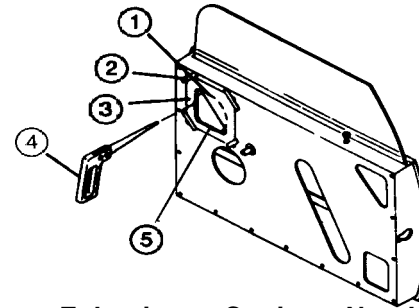

Enlarging or Cutting a New Hole

1. Enlarge or cut new hole per template
2. Tape
3. Template
4. Metal cutting saw
5. File hole smooth after cutting

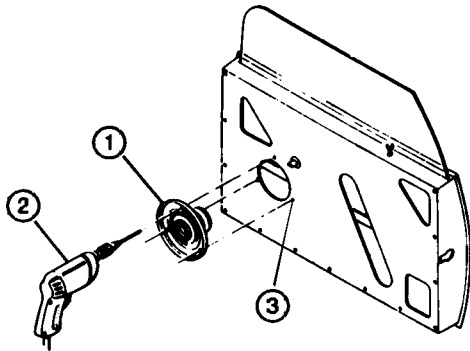

Using an Existing Hole

1. Speaker
2. Drill
3. Drill the required speaker mounting holes

Cutting Door Padding and Piercing Speaker Mounting Holes

After routing the speaker wires, perform the final installation as follows:

1. Replace door panel, window crank, etc. Press against door panel to locate speaker hole. Then, using a sharp knife or box cutter, cut out opening in padded door panel.
2. Replace speaker in opening and pierce the three or four speaker mounting holes. Remove speaker.

Routing Speaker Wires

Route the speaker wires as follows:

1. Route speaker wires from stereo into door. If possible, use existing wires. If door is not equipped with grommets, drill a 1/4" hole in door edge and door frame.
2. Connect wires to speaker per stereo wiring instructions. Allow enough slack between door edge and frame to fully open door. DO NOT tape wires to hinges or braces.

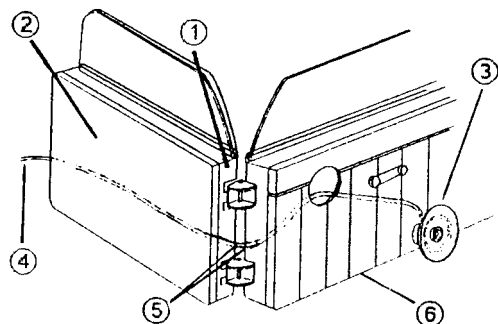

Routing Speaker Wires

1. Door Frame
2. Kick Panel
3. Connect speaker wires to speakers
4. Route wires to stereo
5. Drill 1/4" hole or use existing grommets
6. Door (open)

3. Place speaker into door and secure using screws (and clips, if necessary) provided with speaker.
4. Test the speaker. Then install grille (grille snaps over outer ring of speaker frame). Repeat for remaining door.

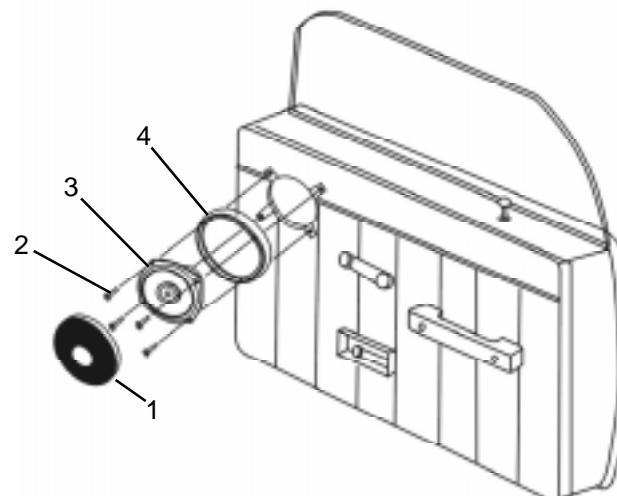

Securing Speaker and Grille

1. Mesh Grille
2. Speaker mounting screws
3. Speaker
4. Grille

Speaker Mounting Details

The following illustrations define the requirements for mounting the speaker on the near and far sides of the mounting surface or independent mounting board.

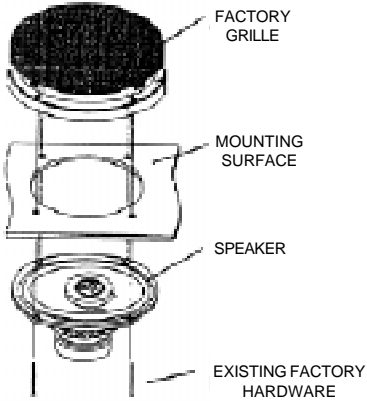

FACTORY SPEAKER REPLACEMENT

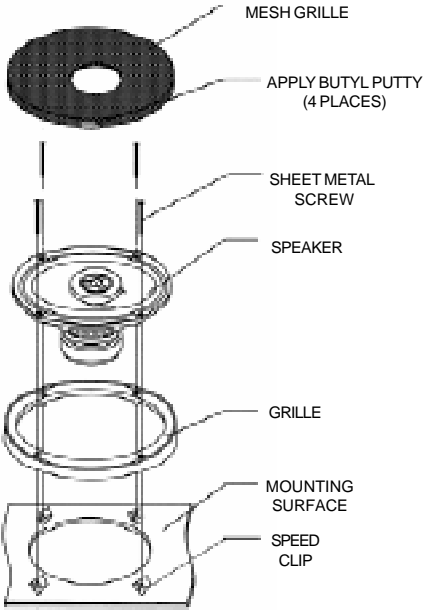
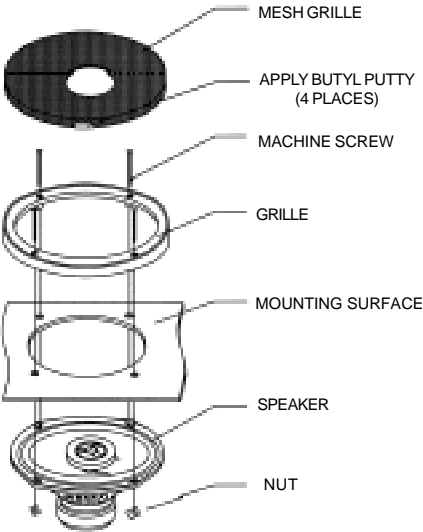

TYPICAL SPEAKER INSTALLATION



AUDIOVOX CORPORATION (the Company) warrants to the original retail purchaser of this product that should this product or any part thereof, under normal use and conditions, be proven defective in material or workmanship within 12 months from the date of original purchase, such defect(s) will be repaired or replaced with new or reconditioned product (at the Company's option) without charge for parts and repair labor.

To obtain repair or replacement within the terms of this Warranty, the product is to be delivered with proof of warranty coverage (e.g. dated bill of sale), specification of defect(s), transportation prepaid, to the warranty center at the address shown below.

This Warranty does not extend to the elimination of car static or motor noise, to correction of antenna problems, to costs incurred for installation, removal, or reinstallation of the product, or damage to tapes, compact discs, accessories, or vehicle electrical systems.

This Warranty does not apply to any product or part thereof which, in the opinion of the Company, has suffered or been damaged through alteration, improper installation, mishandling, misuse, neglect, accident, or by removal or defacement of the factory serial number/bar code label(s) or markings. THE EXTENT OF THE COMPANY'S LIABILITY UNDER THIS WARRANTY IS LIMITED TO THE REPAIR OR REPLACEMENT PROVIDED ABOVE AND, IN NO EVENT, SHALL THE COMPANY'S LIABILITY EXCEED THE PURCHASE PRICE PAID BY PURCHASER FOR THE PRODUCT.

This Warranty is in lieu of all other express warranties or liabilities. ANY IMPLIED WARRANTIES, INCLUDING ANY IMPLIED WARRANTY OF MERCHANTABILITY, SHALL BE LIMITED TO THE DURATION OF THIS WRITTEN WARRANTY. ANY ACTION FOR BREACH OF ANY WARRANTY HEREUNDER INCLUDING ANY IMPLIED WARRANTY OF MERCHANTABILITY MUST BE BROUGHT WITHIN A PERIOD OF 30 MONTHS FROM DATE OF ORIGINAL PURCHASE. IN NO CASE SHALL THE COMPANY BE LIABLE FOR ANY CONSEQUENTIAL OR INCIDENTAL DAMAGES FOR BREACH OF THIS OR ANY OTHER WARRANTY, EXPRESS OR IMPLIED, WHATSOEVER. No person or representative is authorized to assume for the Company any liability other than expressed herein in connection with the sale of this product.

Some states do not allow limitations on how long an implied warranty lasts or the exclusion or limitation of incidental or consequential damage so the above limitations or exclusions may not apply to you. This Warranty gives you specific legal rights and you may also have other rights which vary from state to state.

U.S.A. : AUDIOVOX CORPORATION, 150 MARCUS BLVD., HAUPPAUGE, NY 11788 • 1-800-645-4994
CANADA : CALL 1-800-645-4994 FOR LOCATION OF WARRANTY STATION SERVING YOUR AREA

Form No. 128-4502B